

1,048,576 WORD × 4 BIT DYNAMIC RAM

* This is advanced information and specifications are subject to change without notice.

DESCRIPTION

The TC514400AP/AJ/ASJ/AZ is the new generation dynamic RAM organized 1,048,576 words by 4 bits. The TC514400AP/AJ/ASJ/AZ utilizes TOSHIBA's CMOS Silicon gate process technology as well as advanced circuit techniques to provide wide operating margins, both internally and to the system user. Multiplexed address inputs permit the TC514400AP/AJ/ASJ/AZ to be packaged in a standard 20 pin plastic DIP, 26/20 pin plastic SOJ (300/350mil) and 20 pin plastic ZIP. The package size provides high system bit densities and is compatible with widely available automated testing and insertion equipment. System oriented features include single power supply of 5V±10% tolerance, direct interfacing capability with high performance logic families such as Schottky TTL.

FEATURES

- 1,048,576 word by 4 bit organization
- Fast access time and cycle time

TC514400AP/AJ/ASJ/AZ - 60		
t _{RAC}	\overline{RAS} Access Time	60ns
t _{AA}	Column Address Access Time	30ns
t _{CAC}	\overline{CAS} Access Time	20ns
t _{RC}	Cycle Time	110ns
t _{PC}	Fast Page Mode Cycle Time	45ns

- Single power supply of 5V±10% with a built-in V_{BB} generator

- Low Power
660mW MAX. Operating (TC514400AP/AJ/ASJ/AZ - 60)
5.5mW MAX. Standby
- Outputs unlatched at cycle end allows two-dimensional chip selection
- Read-Modify-Write, \overline{CAS} before \overline{RAS} refresh, \overline{RAS} -only refresh, Hidden refresh, Fast Page Mode and Test Mode capability
- All inputs and outputs TTL compatible
- 1024 refresh cycles/16ms
- Package TC514400AP : DIP20-P-300C
TC514400AJ : SOJ26-P-350
TC514400ASJ : SOJ26-P-300A
TC514400AZ : ZIP20-P-400A

PIN NAMES

A0~A9	Address Inputs	\overline{OE}	Output Enable
\overline{RAS}	Row Address Strobe	I/O1~I/O4	Data Input/Output
\overline{CAS}	Column Address Strobe	V _{CC}	Power (+ 5V)
WRITE	Read/Write Input	V _{SS}	Ground

PIN CONNECTION (TOP VIEW)

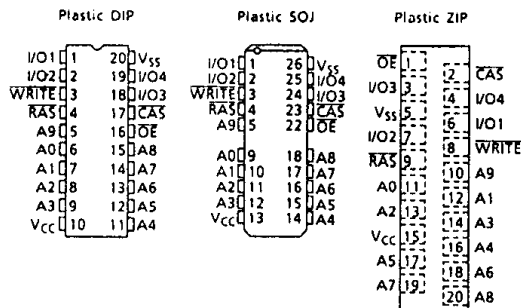

BLOCK DIAGRAM

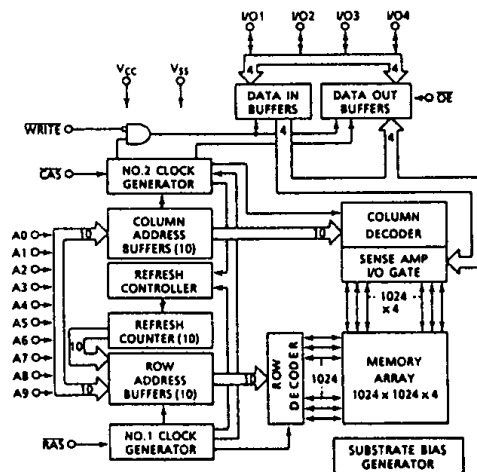

TC514400AP/AJ/ASJ/AZ-60

ABSOLUTE MAXIMUM RATINGS

ITEM	SYMBOL	RATING	UNITS	NOTES
Input Voltage	V_{IN}	-1~7	V	1
Output Voltage	V_{OUT}	-1~7	V	1
Power Supply Voltage	V_{CC}	-1~7	V	1
Operating Temperature	T_{OPR}	0~70	°C	1
Storage Temperature	T_{STG}	-55~150	°C	1
Soldering Temperature · Time	T_{SOLDER}	260 · 10	°C · sec	1
Power Dissipation	P_D	700	mW	1
Short Circuit Output Current	I_{OUT}	50	mA	1

RECOMMENDED DC OPERATING CONDITIONS (Ta = 0~70°C)

SYMBOL	PARAMETER	MIN.	TYP.	MAX.	UNIT	NOTES
V_{CC}	Supply Voltage	4.5	5.0	5.5	V	2
V_{IH}	Input High Voltage	2.4	-	6.5	V	2
V_{IL}	Input Low Voltage	-1.0	-	0.8	V	2

TC514400AP/AJ/ASJ/AZ-60

DC ELECTRICAL CHARACTERISTICS ($V_{CC} = 5V \pm 10\%$, $T_a = 0 \sim 70^\circ\text{C}$)

SYMBOL	PARAMETER	MIN.	MAX.	UNITS	NOTES
I_{CC1}	OPERATING CURRENT Average Power Supply Operating Current (\overline{RAS} , \overline{CAS} , Address Cycling: $t_{RC} = t_{RC}$ MIN.)				
	TC514400AP/AJ/ ASJ/AZ-60	-	120	mA	3, 4 5
I_{CC2}	STANDBY CURRENT Power Supply Standby Current ($\overline{RAS} = \overline{CAS} = V_{IH}$)	-	2	mA	
I_{CC3}	\overline{RAS} ONLY REFRESH CURRENT Average Power Supply Current, \overline{RAS} Only Mode (\overline{RAS} Cycling, $\overline{CAS} = V_{IH}$; $t_{RC} = t_{RC}$ MIN.)				
	TC514400AP/AJ/ ASJ/AZ-60	-	120	mA	3, 5
I_{CC4}	FAST PAGE MODE CURRENT Average Power Supply Current, Fast Page Mode ($\overline{RAS} = V_{IL}$, \overline{CAS} , Address Cycling: $t_{PC} = t_{PC}$ MIN.)				
	TC514400AP/AJ/ ASJ/AZ-60	-	70	mA	3, 4 5
I_{CC5}	STANDBY CURRENT Power Supply Standby Current ($\overline{RAS} = \overline{CAS} = V_{CC} - 0.2V$)	-	1	mA	
I_{CC6}	\overline{CAS} BEFORE \overline{RAS} REFRESH CURRENT Average Power Supply Current, \overline{CAS} Before \overline{RAS} Mode (\overline{RAS} , \overline{CAS} Cycling: $t_{RC} = t_{RC}$ MIN.)				
	TC514400AP/AJ/ ASJ/AZ-60	-	120	mA	3
$I_{I(L)}$	INPUT LEAKAGE CURRENT Input Leakage Current, any input ($0V \leq V_{IN} \leq 6.5V$, All Other Pins Not Under Test = $0V$)	- 10	10	μA	
$I_{O(L)}$	OUTPUT LEAKAGE CURRENT (D_{OUT} is disabled, $0V \leq V_{OUT} \leq 5.5V$)	- 10	10	μA	
V_{OH}	OUTPUT LEVEL Output "H" Level Voltage ($I_{OUT} = -5mA$)	2.4	-	V	
V_{OL}	OUTPUT LEVEL Output "L" Level Voltage ($I_{OUT} = 4.2mA$)	-	0.4	V	

TC514400AP/AJ/ASJ/AZ-60

ELECTRICAL CHARACTERISTICS AND RECOMMENDED AC OPERATING CONDITIONS

($V_{CC} = 5V \pm 10\%$, $T_a = 0 \sim 70^\circ\text{C}$) (Notes 6, 7, 8)

SYMBOL	PARAMETER	TC514400AP/AJ/ASJ/AZ-60		UNIT	NOTES
		MIN.	MAX.		
t_{RC}	Random Read or Write Cycle Time	110	-	ns	
t_{RMW}	Read-Modify-Write Cycle Time	165	-	ns	
t_{PC}	Fast Page Mode Cycle Time	45	-	ns	
t_{PRMW}	Fast Page Mode Read-Modify-Write Cycle Time	100	-	ns	
t_{RAC}	Access Time from \overline{RAS}	-	60	ns	9,14 15
t_{CAC}	Access Time from \overline{CAS}	-	20	ns	9,14
t_{AA}	Access Time from Column Address	-	30	ns	9,15
t_{CPA}	Access Time from \overline{CAS} Precharge	-	40	ns	9
t_{CLZ}	\overline{CAS} to output in Low-Z	0	-	ns	9
t_{OFF}	Output Buffer Turn-off Delay	0	20	ns	10
t_T	Transition Time (Rise and Fall)	3	50	ns	8
t_{RP}	\overline{RAS} Precharge Time	40	-	ns	
t_{RAS}	\overline{RAS} Pulse Width	60	10,000	ns	
t_{RASP}	\overline{RAS} Pulse Width (Fast Page Mode)	60	200,000	ns	
t_{RSH}	\overline{RAS} Hold Time	20	-	ns	
t_{RHCP}	\overline{RAS} Hold Time From \overline{CAS} Precharge (Fast Page Mode)	40	-	ns	
t_{CSH}	\overline{CAS} Hold Time	60	-	ns	
t_{CAS}	\overline{CAS} Pulse Width	20	10,000	ns	
t_{RCD}	\overline{RAS} to \overline{CAS} Delay Time	20	40	ns	14
t_{RAD}	\overline{RAS} to Column Address Delay Time	15	30	ns	15
t_{CRP}	\overline{CAS} to \overline{RAS} Precharge Time	5	-	ns	
t_{CP}	\overline{CAS} Precharge Time	10	-	ns	
t_{ASR}	Row Address Set-Up Time	0	-	ns	
t_{RAH}	Row Address Hold Time	10	-	ns	
t_{ASC}	Column Address Set-Up Time	0	-	ns	
t_{CAH}	Column Address Hold Time	15	-	ns	
t_{RAL}	Column Address to \overline{RAS} Lead Time	30	-	ns	
t_{RCS}	Read Command Set-Up Time	0	-	ns	
t_{RCH}	Read Command Hold Time	0	-	ns	11
t_{RRH}	Read Command Hold Time referenced to \overline{RAS}	0	-	ns	11
t_{WCH}	Write Command Hold Time	10	-	ns	

TC514400AP/AJ/ASJ/AZ-60

ELECTRICAL CHARACTERISTICS AND RECOMMENDED AC OPERATING CONDITIONS

(Continued)

SYMBOL	PARAMETER	TC514400AP/AJ/ASJ/AZ-60		UNITS	NOTES
		MIN.	MAX.		
t _{WP}	Write Command Pulse Width	10	–	ns	
t _{RWL}	Write Command to \overline{RAS} Lead Time	20	–	ns	
t _{CWL}	Write Command to \overline{CAS} Lead Time	20	–	ns	
t _{DS}	Data Set-Up Time	0	–	ns	12
t _{DH}	Data Hold Time	15	–	ns	12
t _{REF}	Refresh Period	–	16	ms	
t _{WCS}	Write Command Set-Up Time	0	–	ns	13
t _{CWD}	\overline{CAS} to \overline{WRITE} Delay Time	50	–	ns	13
t _{RWD}	\overline{RAS} to \overline{WRITE} Delay Time	90	–	ns	13
t _{AWD}	Column Address to \overline{WRITE} Delay Time	60	–	ns	13
t _{CPWD}	\overline{CAS} Precharge to \overline{WRITE} Delay Time	70	–	ns	13
t _{CSR}	\overline{CAS} Set-Up Time (\overline{CAS} before \overline{RAS} Cycle)	5	–	ns	
t _{CHR}	\overline{CAS} Hold Time (\overline{CAS} before \overline{RAS} Cycle)	15	–	ns	
t _{RPC}	\overline{RAS} to \overline{CAS} Precharge Time	0	–	ns	
t _{CPT}	\overline{CAS} Precharge Time (\overline{CAS} before \overline{RAS} Counter Test Cycle)	30	–	ns	
t _{ROH}	\overline{RAS} Hold Time referenced to \overline{OE}	10	–	ns	
t _{OEA}	\overline{OE} Access Time	–	20	ns	
t _{OED}	\overline{OE} to Data Delay	20	–	ns	
t _{OEZ}	Output buffer turn off Delay Time from \overline{OE}	0	20	ns	
t _{OEH}	\overline{OE} Command Hold Time	20	–	ns	
t _{WTS}	Write Command Set-Up Time (Test Mode In)	10	–	ns	
t _{WTH}	Write Command Hold Time (Test Mode In)	10	–	ns	
t _{WRP}	\overline{WRITE} to \overline{RAS} Precharge Time (\overline{CAS} before \overline{RAS} Cycle)	10	–	ns	
t _{WRH}	\overline{WRITE} to \overline{RAS} Hold Time (\overline{CAS} before \overline{RAS} Cycle)	10	–	ns	

TC514400AP/AJ/ASJ/AZ-60

ELECTRICAL CHARACTERISTICS AND RECOMMENDED AC OPERATING CONDITIONS IN THE TEST MODE

SYMBOL	PARAMETER	TC514400AP/AJ/ASJ/AZ-60		UNIT	NOTES
		MIN.	MAX.		
t_{RC}	Random Read or Write Cycle Time	115	-	ns	
t_{PC}	Fast Page Mode Cycle Time	50	-	ns	
t_{RAC}	Access Time from \overline{RAS}	-	65	ns	9,14 15
t_{CAC}	Access Time from \overline{CAS}	-	25	ns	9,14
t_{AA}	Access Time from Column Address	-	35	ns	9,15
t_{CPA}	Access Time from \overline{CAS} Precharge	-	45	ns	9
t_{RAS}	\overline{RAS} Pulse Width	65	10,000	ns	
t_{RASP}	\overline{RAS} Pulse Width (Fast Page Mode)	65	200,000	ns	
t_{RSH}	\overline{RAS} Hold Time	25	-	ns	
t_{CSH}	\overline{CAS} Hold Time	65	-	ns	
t_{RHCP}	\overline{RAS} Hold Time From \overline{CAS} Precharge (Fast Page Mode)	45	-	ns	
t_{CAS}	\overline{CAS} Pulse Width	25	10,000	ns	
t_{RAL}	Column Address to \overline{RAS} Lead Time	35	-	ns	

CAPACITANCE ($V_{CC} = 5V \pm 10\%$, $f = 1MHz$, $T_a = 0 \sim 70^\circ C$)

SYMBOL	PARAMETER	MIN.	MAX.	UNIT
C_{I1}	Input Capacitance (A0~A9)	-	5	pF
C_{I2}	Input Capacitance (\overline{RAS} , \overline{CAS} , WRITE, \overline{OE})	-	7	pF
C_O	Input/Output Capacitance (I/O1~I/O4)	-	7	pF

NOTES:

1. Stresses greater than those listed under "Absolute Maximum Ratings" may cause permanent damage to the device.
2. All voltages are referenced to V_{SS} .
3. ICC_1 , ICC_3 , ICC_4 , ICC_6 depend on cycle rate.
4. ICC_1 , ICC_4 depend on output loading. Specified values are obtained with the output open.
5. Column address can be changed once or less while $\overline{RAS} = V_{IL}$ and $\overline{CAS} = V_{IH}$.
6. An initial pause of 200 μ s is required after power-up followed by 8 \overline{RAS} only refresh cycles before proper device operation is achieved. In case of using internal refresh counter, a minimum of 8 \overline{CAS} before \overline{RAS} refresh cycles instead of 8 \overline{RAS} only refresh cycles are required.
7. AC measurements assume $t_T = 5$ ns.
8. V_{IH} (min.) and V_{IL} (max.) are reference levels for measuring timing of input signals. Also, transition times are measured between V_{IH} and V_{IL} .
9. Measured with a load equivalent to 2 TTL loads and 100pF.
10. t_{OFF} (max.) and t_{OEZ} (max.) define the time at which the output achieves the open circuit condition and are not referenced to output voltage levels.
11. Either t_{RCH} or t_{RRH} must be satisfied for a read cycle.
12. These parameters are referenced to \overline{CAS} leading edge in early write cycles and to \overline{WRITE} leading edge in Read-Modify-Write cycles.
13. t_{WCS} , t_{RWD} , t_{CWD} , t_{AWD} and t_{CPWD} are not restrictive operating parameters. They are included in the data sheet as electrical characteristics only. If $t_{WCS} \geq t_{WCS}(\text{min.})$, the cycle is an early write cycle and the data out pin will remain open circuit (high impedance) through the entire cycle; If $t_{RWD} \geq t_{RWD}(\text{min.})$, $t_{CWD} \geq t_{CWD}(\text{min.})$, $t_{AWD} \geq t_{AWD}(\text{min.})$ and $t_{CPWD} \geq t_{CPWD}(\text{min.})$ (Fast Page Mode), the cycle is a Read-Modify-Write cycle and the data out will contain data read from the selected cell: If neither of the above sets of conditions is satisfied, the condition of the data out (at access time) is indeterminate.
14. Operation within the $t_{RCD}(\text{max.})$ limit insures that $t_{RAC}(\text{max.})$ can be met. $t_{RCD}(\text{max.})$ is specified as a reference point only: If t_{RCD} is greater than the specified $t_{RCD}(\text{max.})$ limit, then access time is controlled by t_{CAC} .
15. Operation within the $t_{RAD}(\text{max.})$ limit insures that $t_{RAC}(\text{max.})$ can be met. $t_{RAD}(\text{max.})$ is specified as a reference point only: If t_{RAD} is greater than the specified $t_{RAD}(\text{max.})$ limit, then access time is controlled by t_{AA} .

TC514400AP/AJ/ASJ/AZ-60

READ CYCLE

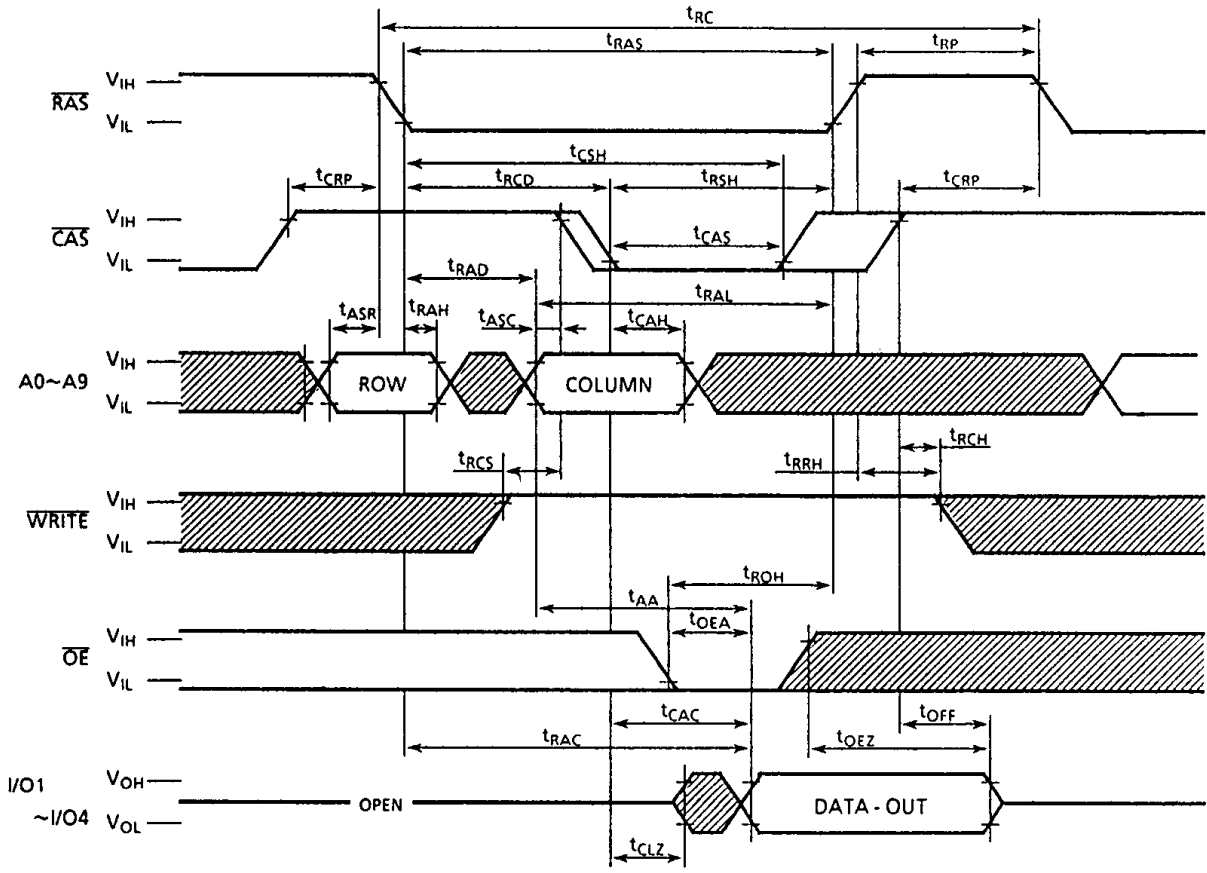

▨ : "H" or "L"

WRITE CYCLE (EARLY WRITE)

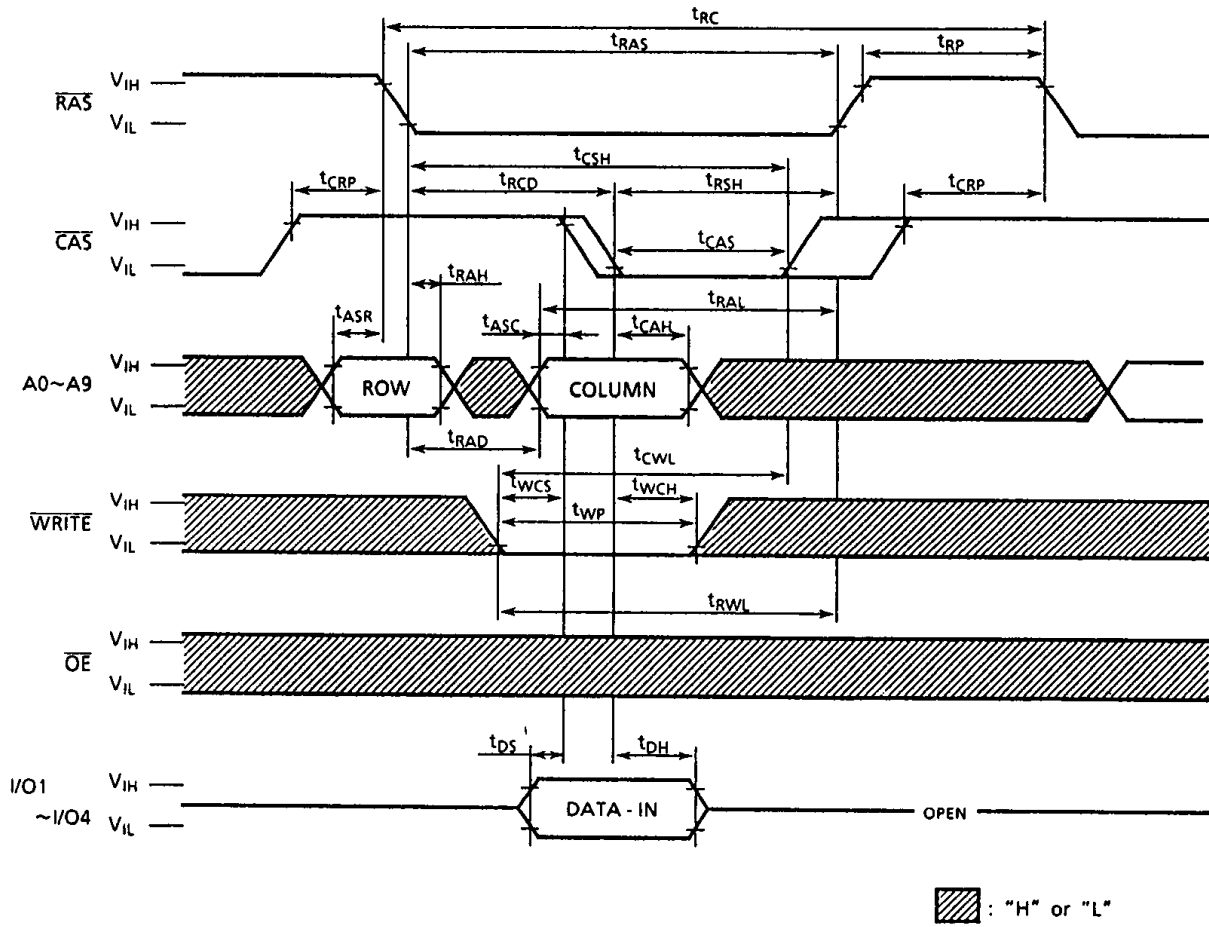

TC514400AP/AJ/ASJ/AZ-60

WRITE CYCLE (\overline{OE} CONTROLLED WRITE)

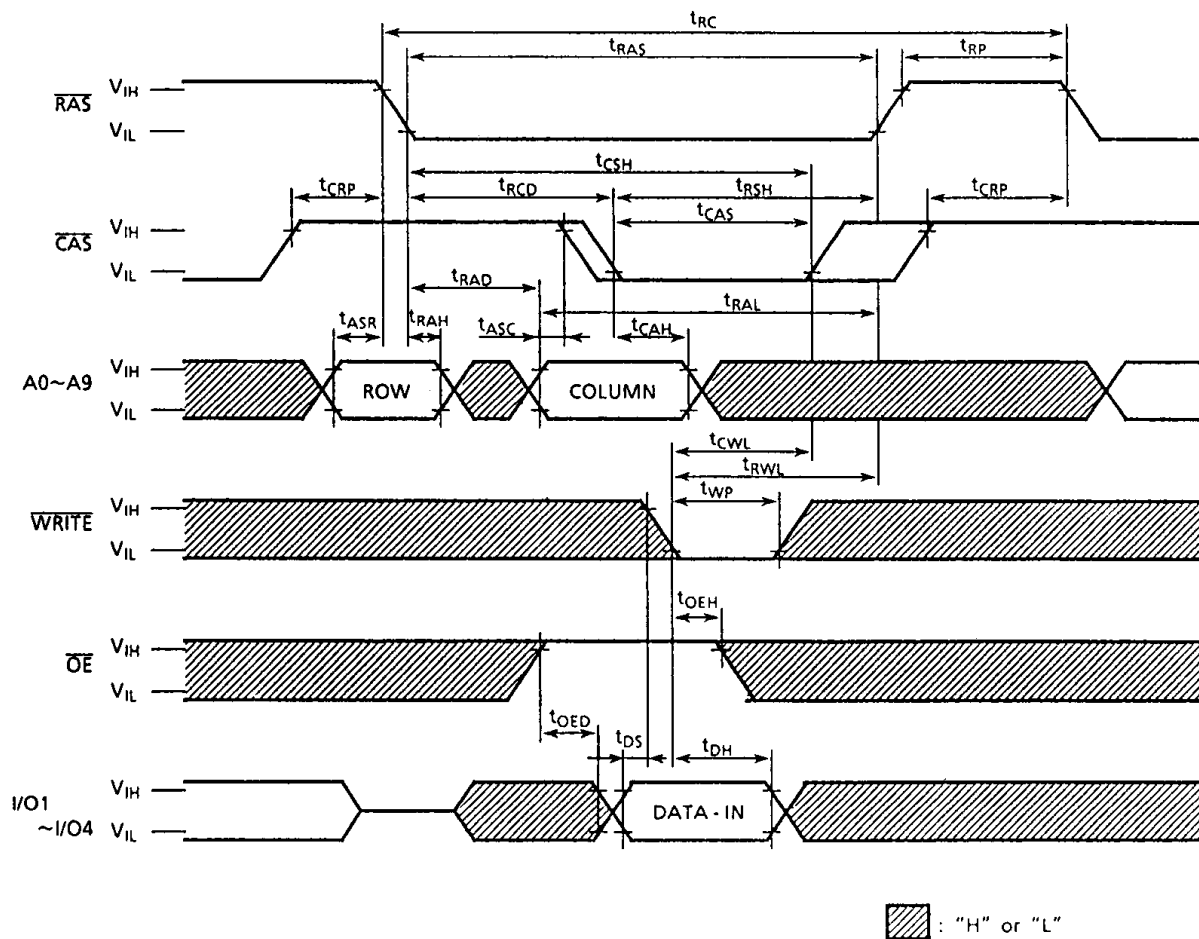

READ-MODIFY-WRITE CYCLE

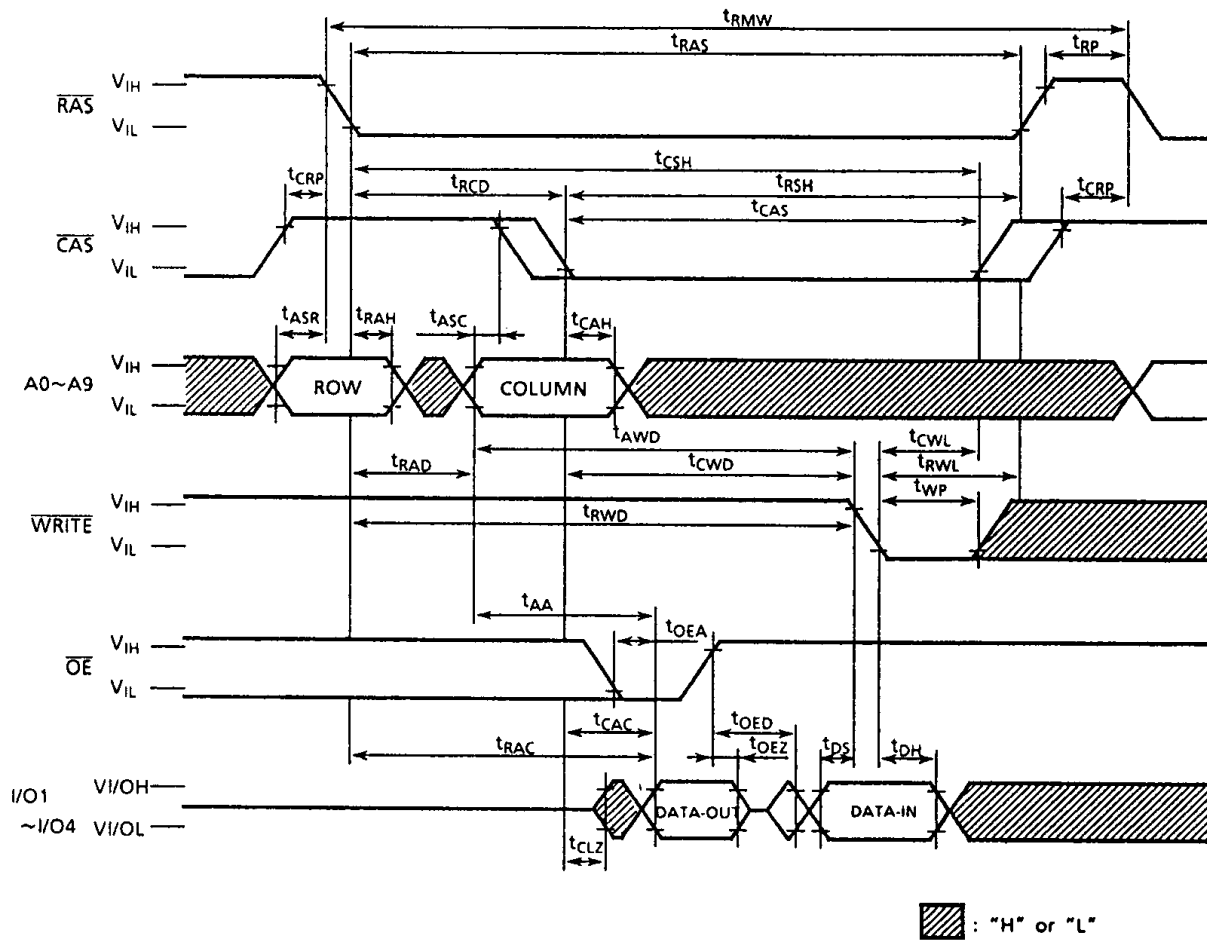

TC514400AP/AJ/ASJ/AZ-60

FAST PAGE MODE READ CYCLE

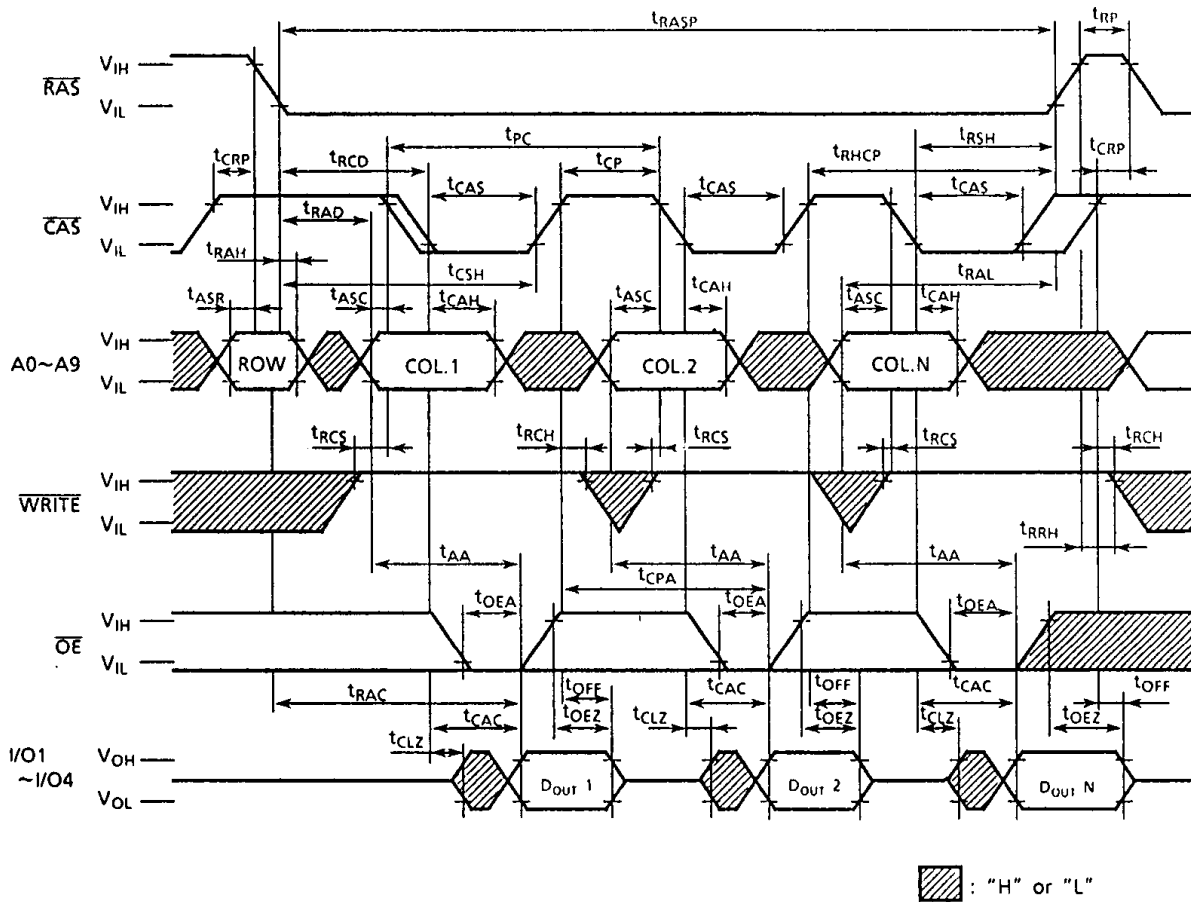

FAST PAGE MODE WRITE CYCLE

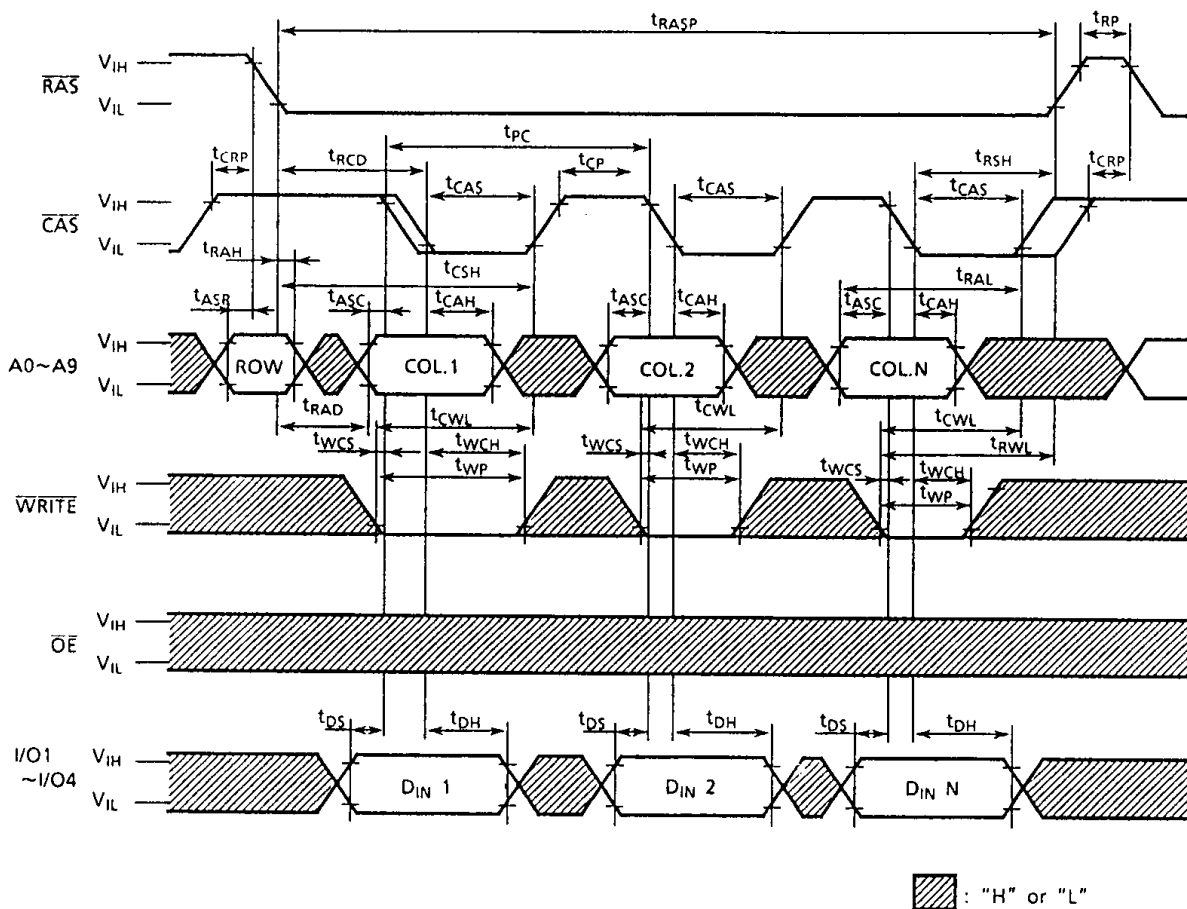

TC514400AP/AJ/ASJ/AZ-60

FAST PAGE MODE READ-MODIFY-WRITE CYCLE

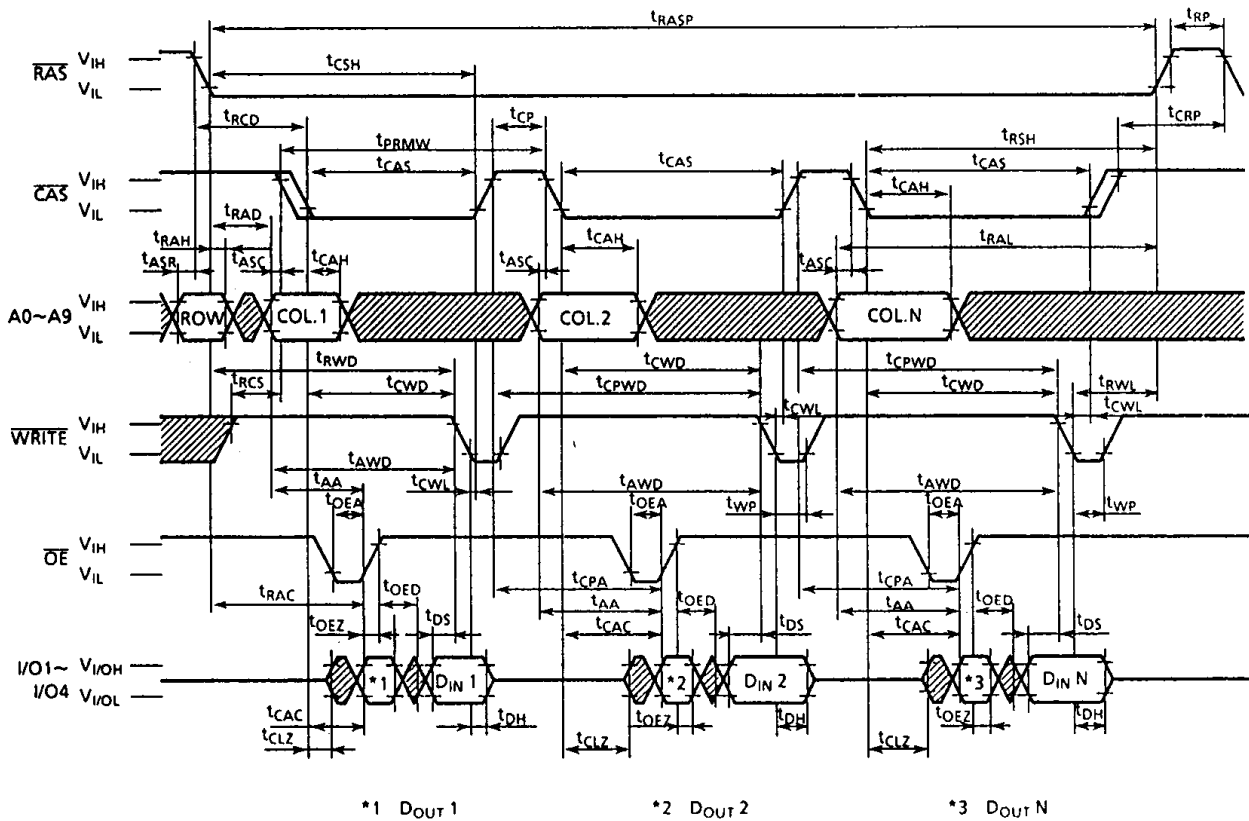

RAS ONLY REFRESH CYCLE

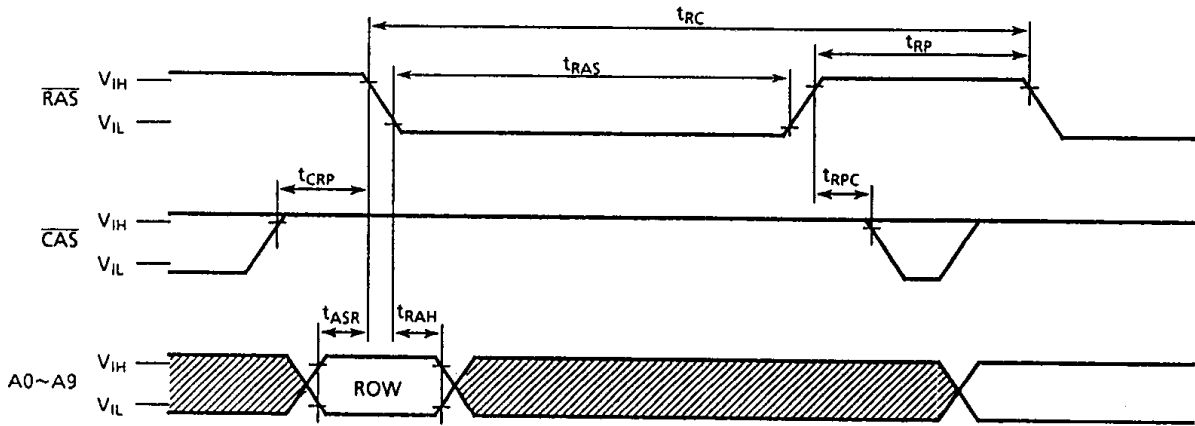

Note: WRITE, OE = "H" or "L"

▨ : "H" or "L"

CAS BEFORE RAS REFRESH CYCLE

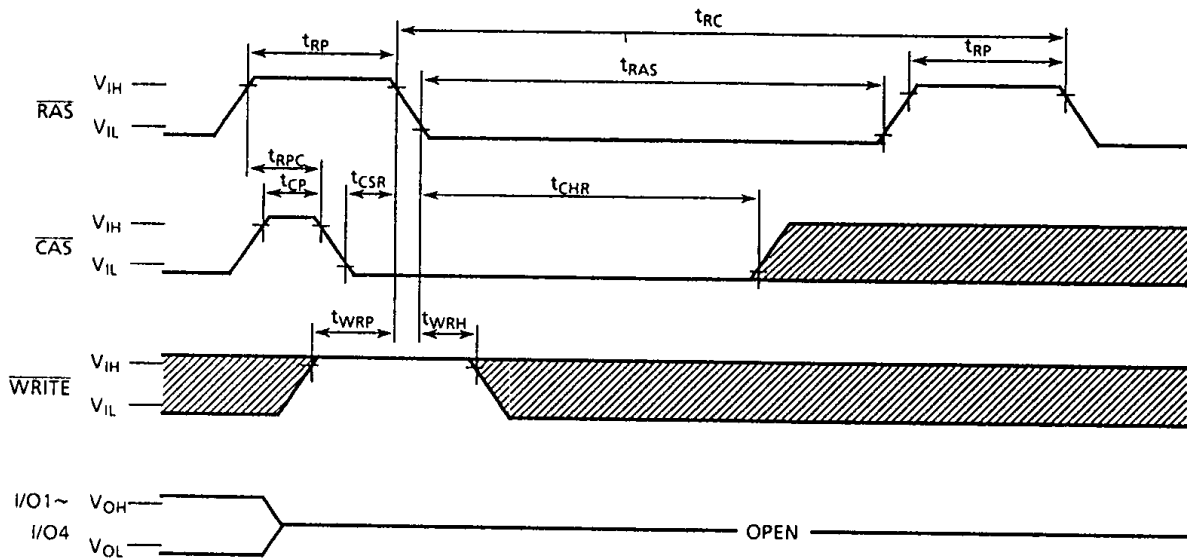

Note: OE, A0~A9 = "H" or "L"

▨ : "H" or "L"

TC514400AP/AJ/ASJ/AZ-60

HIDDEN REFRESH CYCLE (READ)

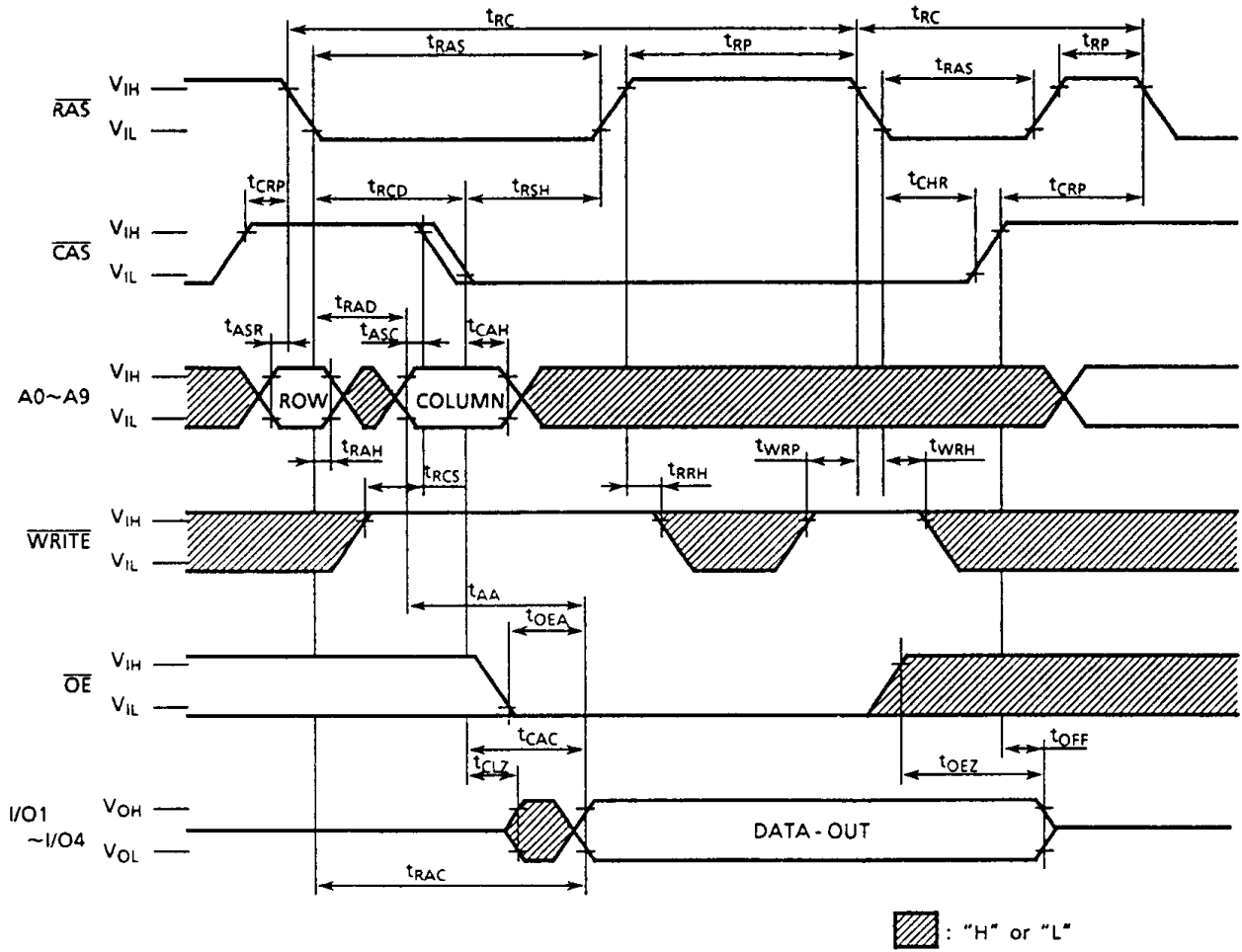

HIDDEN REFRESH CYCLE (WRITE)

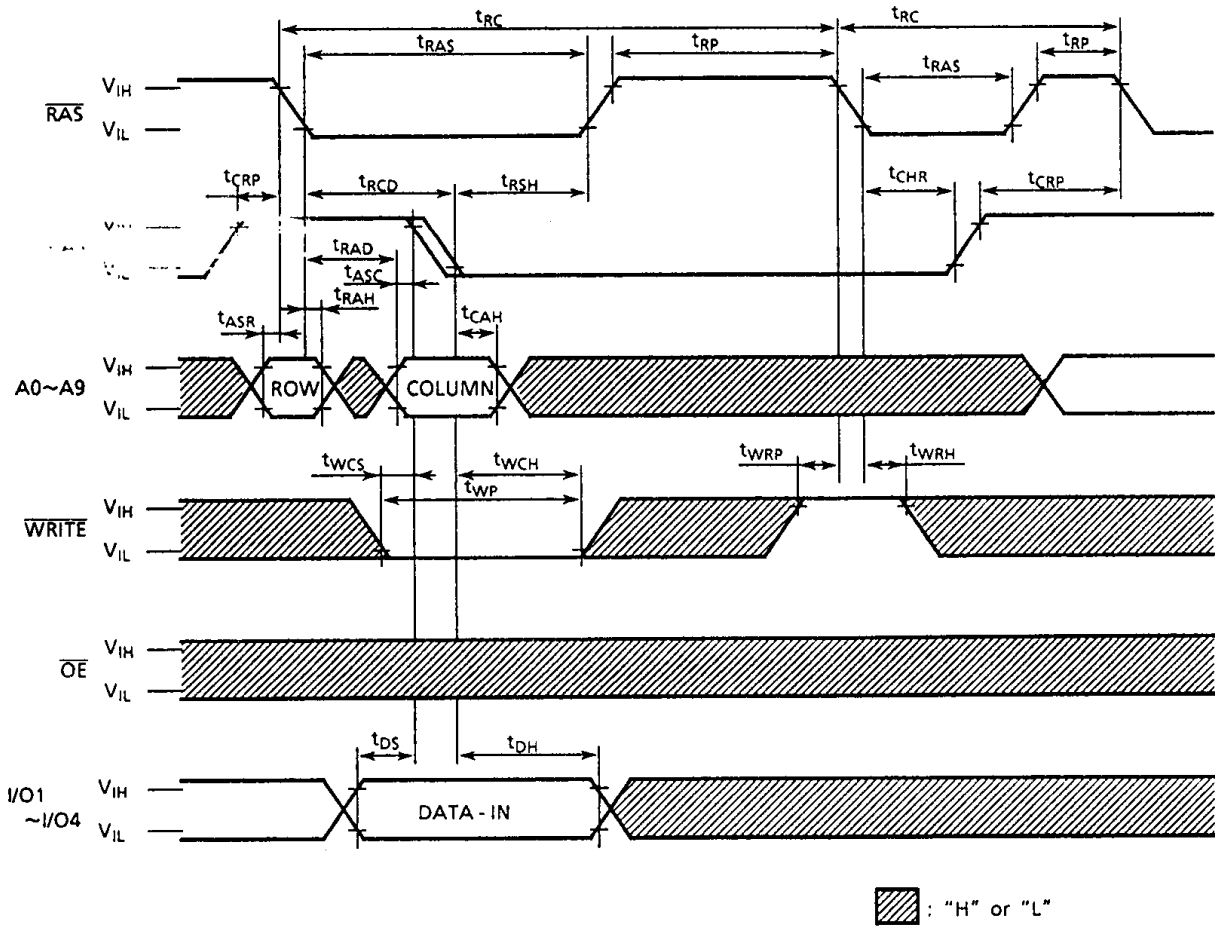

TC514400AP/AJ/ASJ/AZ-60

CAS BEFORE RAS REFRESH COUNTER TEST CYCLE

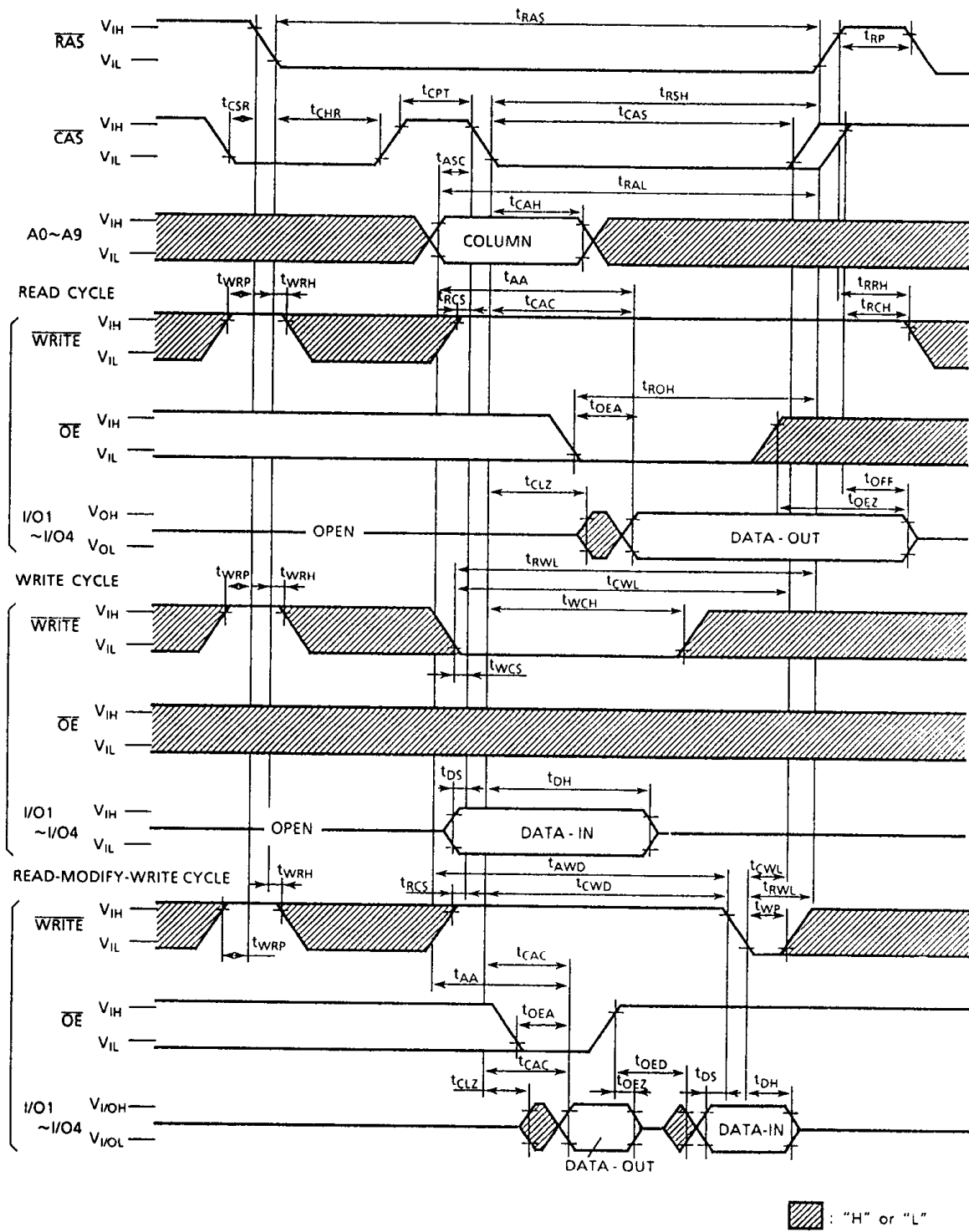

WRITE, CAS BEFORE RAS REFRESH CYCLE

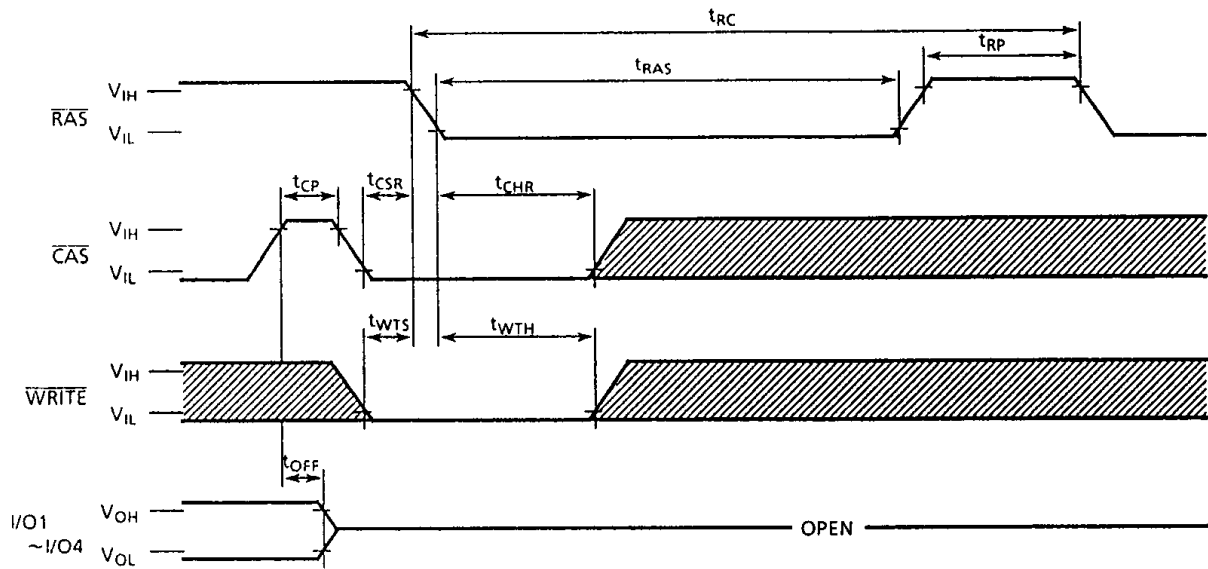

Note: \overline{OE} , A0~A9 = "H" or "L"

 : "H" or "L"

TC514400AP/AJ/ASJ/AZ-60

TEST MODE

The TC514400AP/AJ/ASJ/AZ is the RAM organized 1,048,576 words by 4 bits, it is internally organized 524,288 words by 8 bits. In "Test Mode", data are written into 8 sectors in parallel and retrieved the same way. A0c is not used. If, upon reading, two bits on one I/O pin are equal (all "1"s or "0"s), the I/O pin indicates a "1".

If they were not equal, the I/O pin would indicate a "0". Fig.1 shows the block diagram of TC514400AP/AJ/ASJ/AZ. In "Test Mode", the 1M×4 DRAM can be tested as if it were a 512K×4 DRAM.

" $\overline{\text{WRITE}}$, $\overline{\text{CAS}}$ Before $\overline{\text{RAS}}$ Refresh Cycle" puts the device into "Test Mode". And " $\overline{\text{CAS}}$ Before $\overline{\text{RAS}}$ Refresh Cycle" or " $\overline{\text{RAS}}$ Only Refresh Cycle" puts it back into "Normal Mode". In the Test Mode, " $\overline{\text{WRITE}}$, $\overline{\text{CAS}}$ Before $\overline{\text{RAS}}$ Refresh Cycle" Performs the refresh operation with the internal refresh address counter. The "Test Mode" function reduces test times (1/2 in case of N test pattern).

BLOCK DIAGRAM IN THE TEST MODE

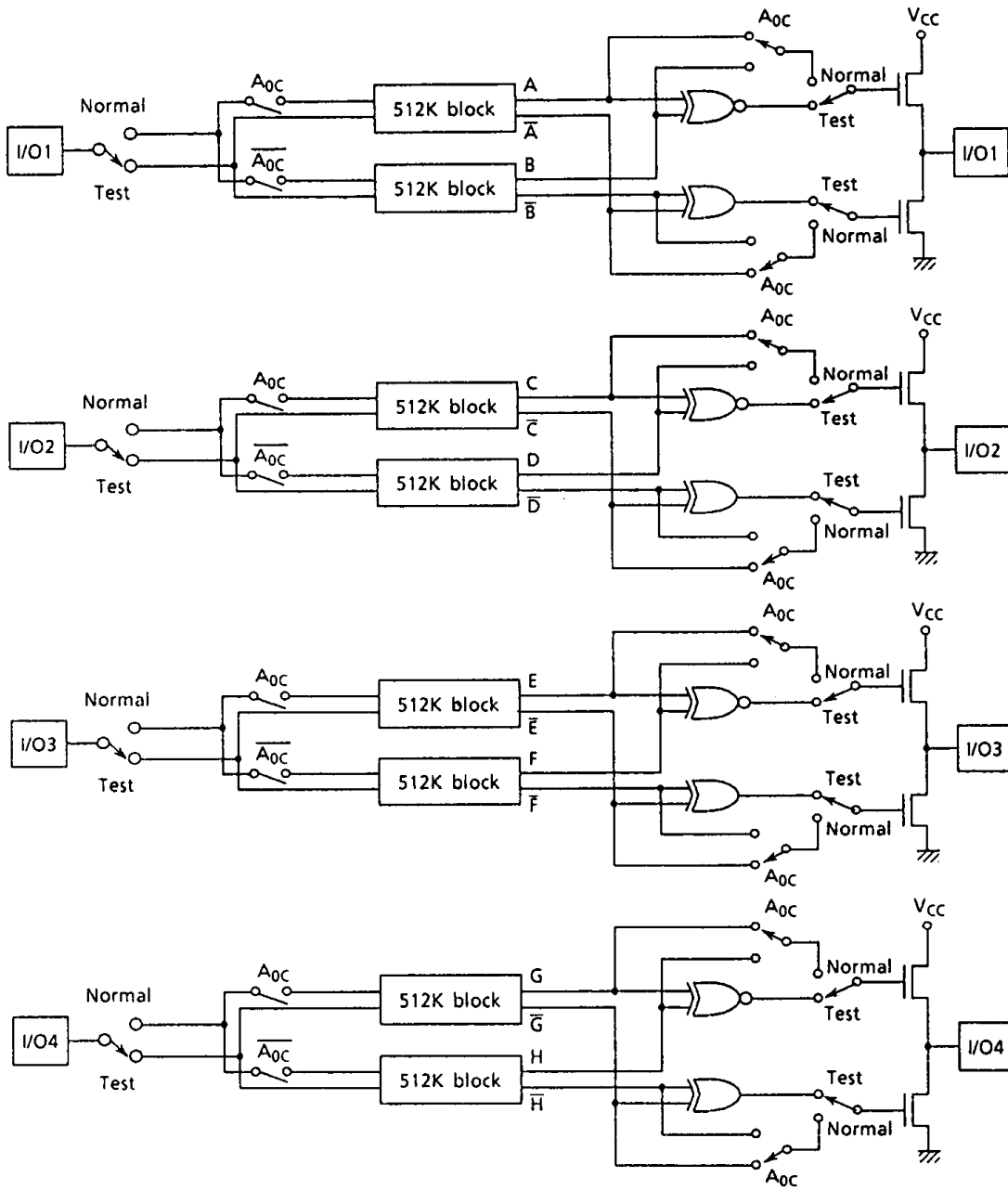

Fig. 1